



## INTERNATIONAL ETHELLES CLASS



## ICE BUCKET

organised by  
**COWES CORINTHIAN YACHT CLUB**

**Saturday 24<sup>TH</sup> October - Sunday 25<sup>th</sup> 2020**

# SAILING INSTRUCTIONS

### 1. RULES

- 1.1 The regatta will be governed by the rules as defined in The Racing Rules of Sailing (RRS), the rules of the International Etchells Class Association, the Notice of Race and these Sailing Instructions.
- 1.2 The Associated British Ports Southampton Byelaws current at the start of the first race of the event apply.
- 1.3 Rule 44.1 is changed so that the Two-Turns Penalty is replaced by the One-Turn Penalty except where the breach of the rule occurs within the Zone of any mark other than starting mark.
- 1.4 Boats shall comply with Associated British Ports Notice to Mariners No 14 of 2019: The Moving Prohibited Zone in the Precautionary Area which shall rank as an obstruction for the purposes of rules 19 and 20. Boats shall avoid close quarters with any commercial vessel.
- 1.5 Boats shall not anchor or kedge in Cowes Harbour fairway.
- 1.6 Sails may be borrowed in accordance with Etchells Class Rule C10.3
- 1.7 In the event of conflict between the Notice of Race and these Sailing Instructions, the provisions of these Sailing Instructions shall prevail, changing RRS 63.7.

### 2. NOTICES TO COMPETITORS

Notices to competitors will be posted on the official notice board located at Cowes Yacht Haven.

### 3. CHANGES TO SAILING INSTRUCTIONS

Any change to the sailing instructions will be posted before 09:00 on the day it will take effect, except that any change to the schedule of races will be posted by 12:00 on the day before it will take effect.

### 4. SIGNALS MADE ASHORE

- 4.1 Signals made ashore will be displayed at Cowes Yacht Haven.
- 4.2 When flag AP is displayed ashore, '1 minute' is replaced with 'not less than 60 minutes' in the race signal AP.
- 4.3 When flag Y is displayed ashore, rule 40 applies at all times while afloat. This changes the Part 4 preamble.

### 5. SCHEDULE OF RACES

- 5.1 Racing days will be Saturday 24<sup>th</sup> and Sunday 25<sup>th</sup> October 2020.
- 5.2 It is intended that there will be three races per day; however more than three races may be run on any one day if the Race Committee so decides. Any such decision shall not be the subject of a request for redress changing Rules 60.1 (b) and 62.
- 5.3 There will be a briefing at 08:30 via the WhatsApp Group on Saturday 24<sup>th</sup> October for all competitors.

- 5.4 The scheduled time of the warning signal for the first race on Saturday 24<sup>th</sup> October is 10:25. On Sunday 25<sup>th</sup> October it is 10:25.
- 5.5 After a long postponement, to alert boats that a race or sequence of races will begin soon, an orange flag will be displayed with one sound for at least five minutes before a warning signal is displayed
- 5.6 On the last day of the regatta no warning signal will be made after 15:00, unless there is a postponement or general recall during a starting sequence.

## **6. CLASS FLAGS**

Class flag will be International Code Flag E.

## **7. RACING AREAS**

Racing area will be in the Central Solent and further described in the briefing.

## **8. THE COURSES**

- 8.1 The diagrams in Attachment A show the courses, including the approximate angles between legs, the order in which marks are to be passed, and the side on which each mark is to be left.
- 8.2 The course to be sailed will be announced on the VHF channel prior to the Warning Signal.
- 8.3 No later than the warning signal, the race committee vessel will display a board showing the the approximate compass bearing of the first leg and course identifier.

## **9. MARKS**

- 9.1 Marks will be orange inflatable buoys, or as described at the briefing.
- 9.2 New marks, as provided for at SI 11, will be black inflatable cylinder.

## **10. THE START**

- 10.1 The starting line will be between the staff displaying an orange flag on the committee boat and a black inflatable mark. An inner distance marker (IDM) may be laid.
- 10.2 A boat starting later than five minutes after her starting signal will be scored Did Not Start without a hearing. This changes rule A4.
- 10.3 The Race Committee may use VHF radio to communicate to the fleet, including the starting area, countdown to the start, OCS bow/sail numbers (to be communicated as soon as practical), general recalls, black flag DSQs and Postponements and change of course. Failure to make these broadcasts or failure to hear them shall not constitute grounds for redress.

## **11. CHANGE OF THE NEXT LEG OF THE COURSE**

- 11.1 To change the next leg of the course, the race committee will lay a new mark (or move the finishing line) and remove the original mark as soon as practicable. When in a subsequent change a new mark is replaced, it will be replaced by an original mark.
- 11.2 Changing Race Signal flag 'C' and RRS 33: the position of any laid inflated mark(s) may be adjusted by up to plus or minus 10 degrees relative to the previous laid mark(s) and up to approximately 500m to windward or leeward without signalling of code flag 'C' or '+' or '-'.  
11.3 If a new windward mark is laid by the race committee, then a spreader mark may not be laid.

## **12. THE FINISH**

The finishing line will be between a staff displaying an orange flag on the Committee Boat and the course side of the finishing mark.

## **13. TIME LIMITS**

- 13.1 The Time limit shall be 90 minutes.
- 13.2 Boats failing to finish within 15 minutes after the first boat sails the course and finishes will be scored Did Not Finish without a hearing. This changes rules 35, A4 and A5.

## 14. PROTESTS AND REQUESTS FOR REDRESS

- 14.1 Protest forms will be available at the Etchells container, located at Cowes Yacht Haven. Protests and requests for redress or reopening shall be delivered there within the appropriate time limit. Contact mobile telephone numbers must be included on the protest form.
- 14.2 The protest time limit is 90 minutes after the last boat has finished the last race of the day or the race committee signals no more racing today, whichever is later.
- 14.3 Notices will be posted no later than 30 minutes after the protest time limit to inform competitors of the hearings in which they are parties or named as witnesses. Hearings will be at the Cowes Corinthian Yacht Club beginning at the time posted.
- 14.4 For infringements of rules other than in Parts 1 and 2 of the RRS, the penalty for a breach of a rule may, at the discretion of the protest committee, be less than disqualification.

## 15. SCORING

- 15.1 Two races are required to be completed to constitute a series.
- 15.2 When fewer than four races have been completed, a boat's series score will be the total of her race scores
- 15.3 When four or more race have been completed, a boat's score will be the total of her race scores excluding her worst score.

## 16. RETIREMENT

A boat that retires from a race shall notify the race committee as soon as possible.

## 17. REPLACEMENT OF CREW OR EQUIPMENT

- 17.1 Substitution of competitors will not be allowed without prior written approval of the race committee.
- 17.2 Substitution of damaged or lost equipment will not be allowed unless authorized by the race committee. Requests for substitution shall be made to the committee at the first reasonable opportunity.
- 17.3 During the Covid restrictions written approval maybe replaced with a WhatsApp communication by the Race Committee.

## 18. EQUIPMENT AND MEASUREMENT CHECKS

A boat or equipment may be inspected at any time for compliance with the class rules and sailing instructions. On the water, a boat can be instructed by a race committee equipment inspector or measurer to proceed immediately to a designated area for inspection.

## 19. HAUL-OUT RESTRICTIONS

Keelboats shall not be hauled out during the regatta except with and according to the terms of prior written permission of the race committee.

## 20. RADIO COMMUNICATION

Except in an emergency, a boat shall neither make radio transmissions while racing nor receive radio communications not available to all boats. This restriction also applies to mobile telephones. The Race Committee will communicate with competitors on VHF channel 72 or such other radio channel as shall be announced at the briefing.

## 21. INSURANCE

Each participating boat shall be insured with valid third-party liability insurance with a minimum cover of £3,000,000 per event.

## 22. COVID Statement

***By taking part in any of the events covered by these Sailing Instructions, each competitor agrees and acknowledges that they are responsible for complying with any regulations in force from time to time in respect of COVID-19 and for complying with Cowes Corinthian Yacht Club COVID-19 procedures.***

***The penalty for a breach of this rule may, at the discretion of the Protest Committee, be less than disqualification. Boats may not protest for breaches of this rule. This changes rule 60.1(a). [DP]***

# Course L

## Attachment A

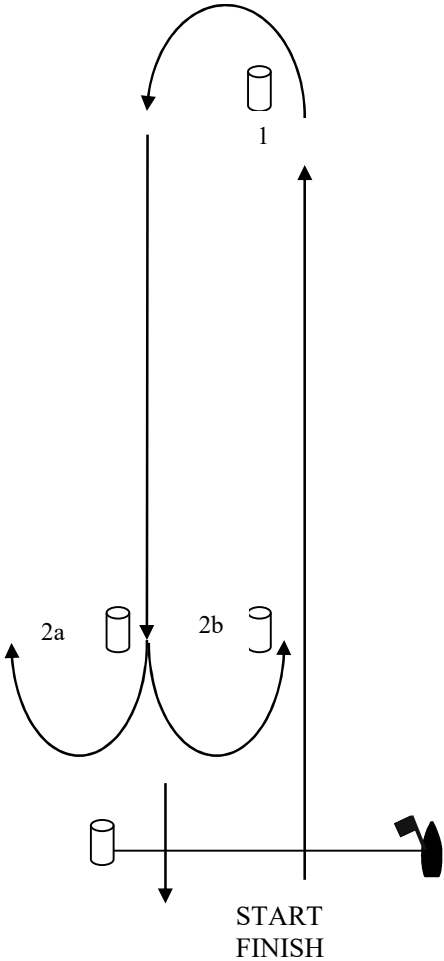

|           |                                     |
|-----------|-------------------------------------|
| <b>L2</b> | 1, (2a, 2b), 1, Finish              |
| <b>L3</b> | 1, (2a, 2b), 1, (2a, 2b), 1, Finish |

# Course LA

Attachment A

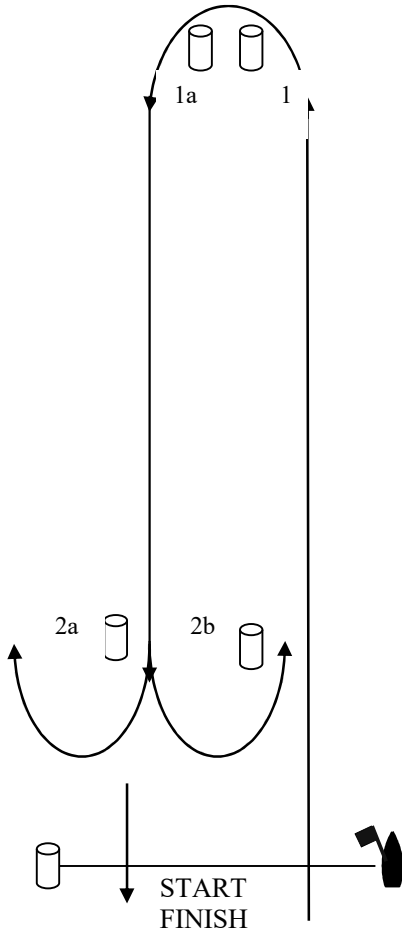

|            |   |
|------------|---|
| <b>LA2</b> | 1, 1a, (2a, 2b), 1, 1a, Finish                  |
| <b>LA3</b> | 1, 1a, (2a, 2b), 1, 1a, (2a, 2b), 1, 1a, Finish |

Course W

Attachment A

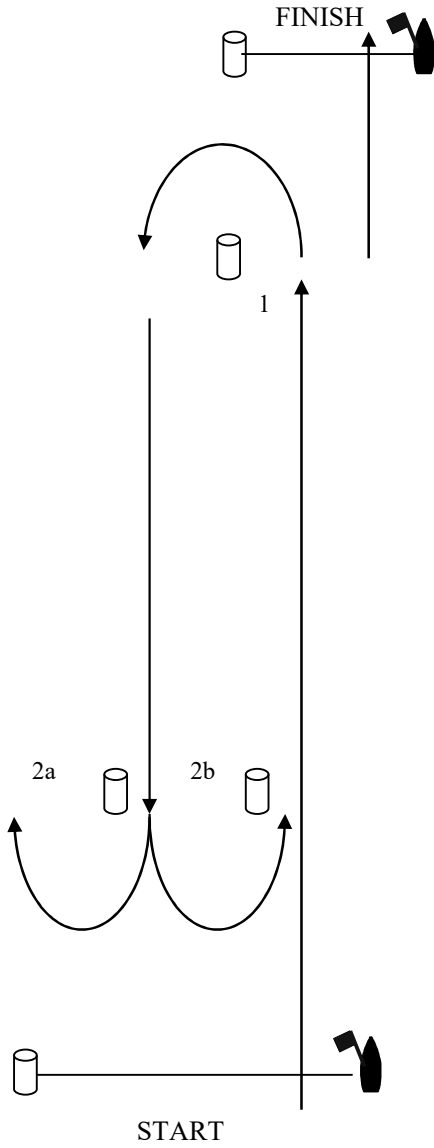

|           |                                  |
|-----------|----------------------------------|
| <b>W2</b> | 1, (2a, 2b), Finish              |
| <b>W3</b> | 1, (2a, 2b), 1, (2a, 2b), Finish |

# Attachment A

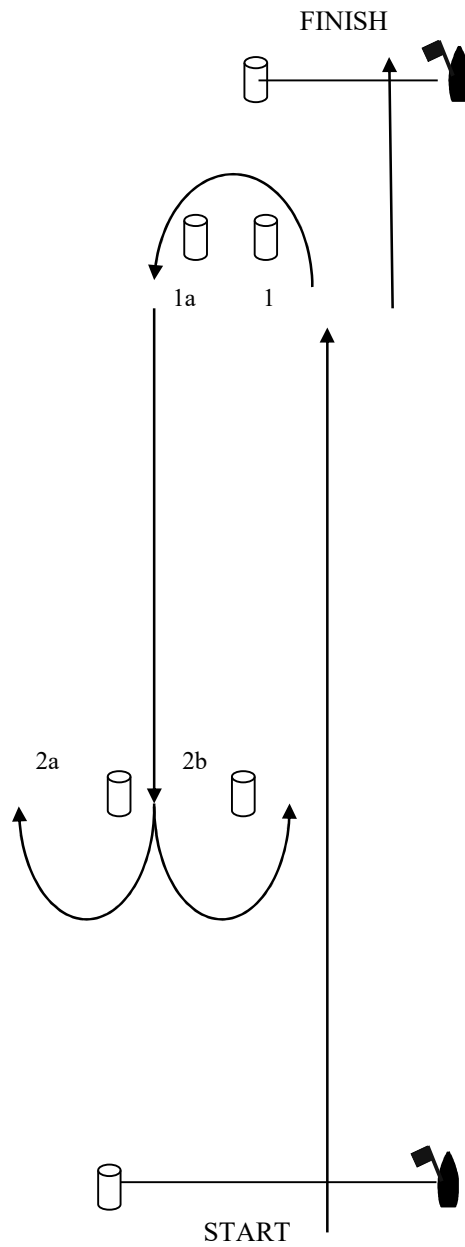

|            |   |
|------------|---|
| <b>WA2</b> | 1, 1a, (2a, 2b), Finish                 |
| <b>WA3</b> | 1, 1a, (2a, 2b), 1, 1a (2a, 2b), Finish |